

修订 REV	标记 MARK	修改摘要 REVISION DESCRIPTION	签名 SIGNATURE	日期 DATE
AO		NEW RELEASE	WANG	2017-07-26

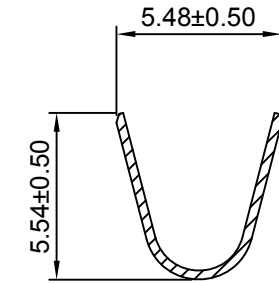

SEC:A-A

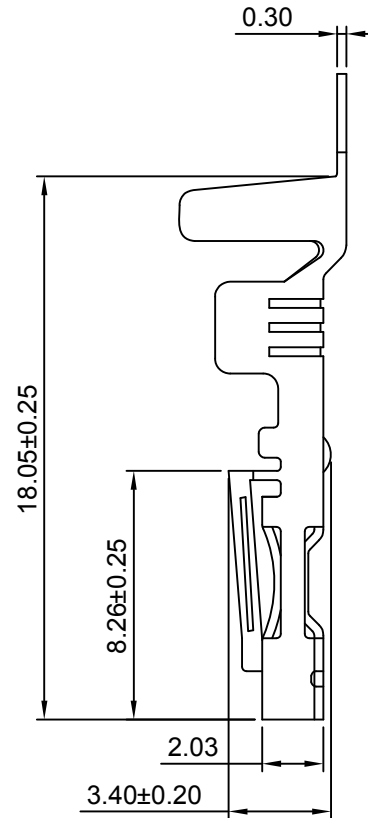
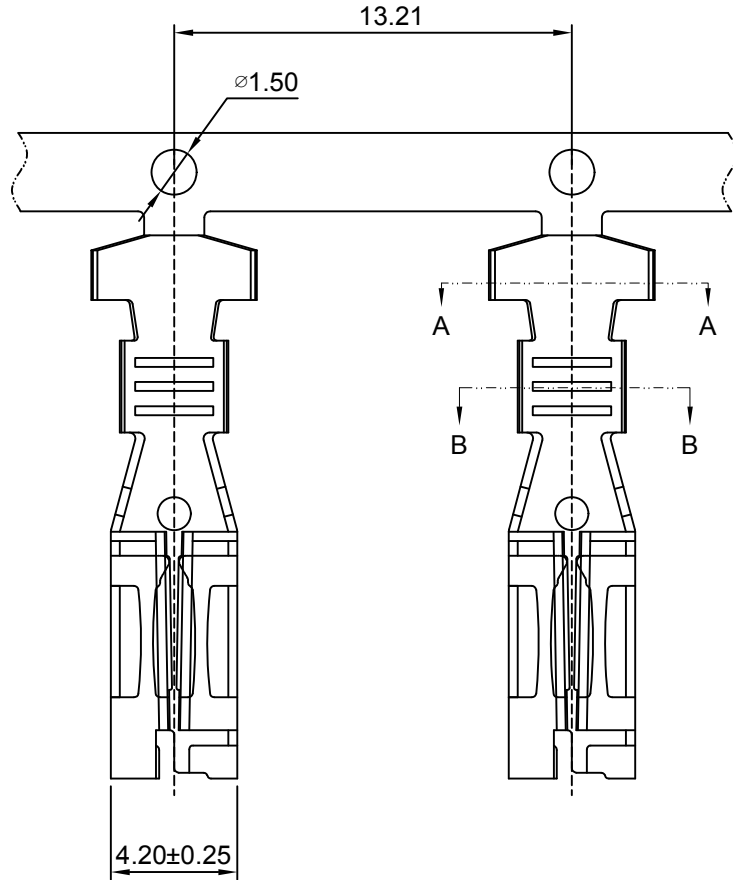
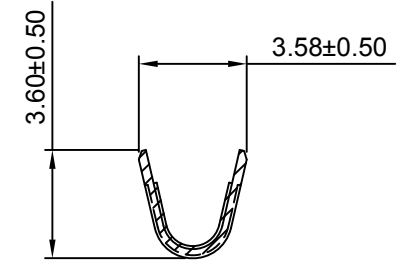

SEC:B-B

Ordering information & Specifications

Unit:mm

Part No	Wire Range	Insultion O.D.	Material	Finish	Qty/reel
HDGC7501AF-TB	AWG#14~#16	4.57mm(max)	Brass	Tin over Nickel	5,000 PCS



深圳市华德共创科技有限公司

SHENZHEN HUADE CO-CREATE TECHNOLOGY CO.,LTD

TEL : 0755-27129737 FAX : 0755-29940187

-TOLERANCES- UNLESS OTHERWISE SPECIFIED 公差参数表						TITLE: 7.50mm Pitch 产品名称: Crimp Terminal			
X.X	± 0.30	X.X°	$\pm 3^\circ$	APPD: 核准:	XIE	PART NO: 产品编号: HDGC7501AF-T			
X.XX	± 0.30	X.XX°	$\pm 2^\circ$	CHECK: 校对:	WANG	DATE	SCALE	UNIT	CODE NUMBER
X.XXX	± 0.10	X.XXX°	$\pm 1^\circ$	DRAW: 绘图:	WANG	2017-07-26	4:1	mm	A008

修订 REV	标记 MARK	修改摘要 REVISION DESCRIPTION	签名 SIGNATURE	日期 DATE
AO		NEW RELEASE	WANG	2017-07-26

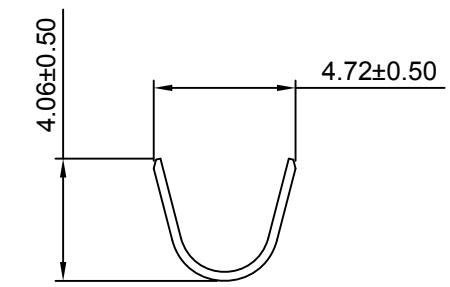
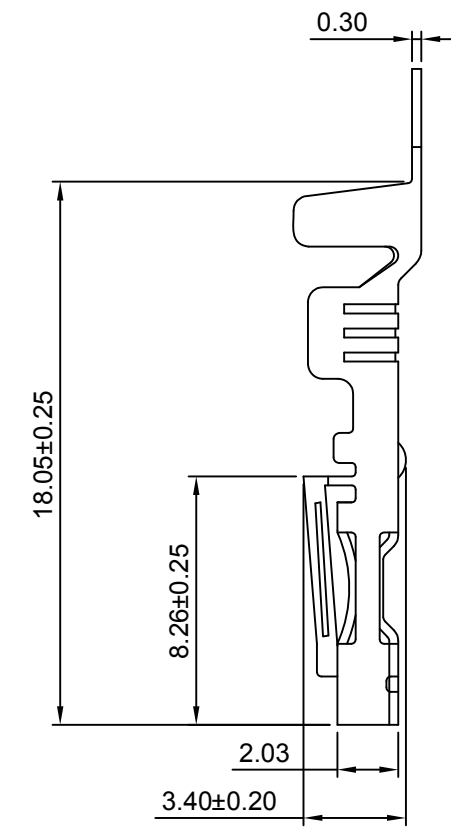
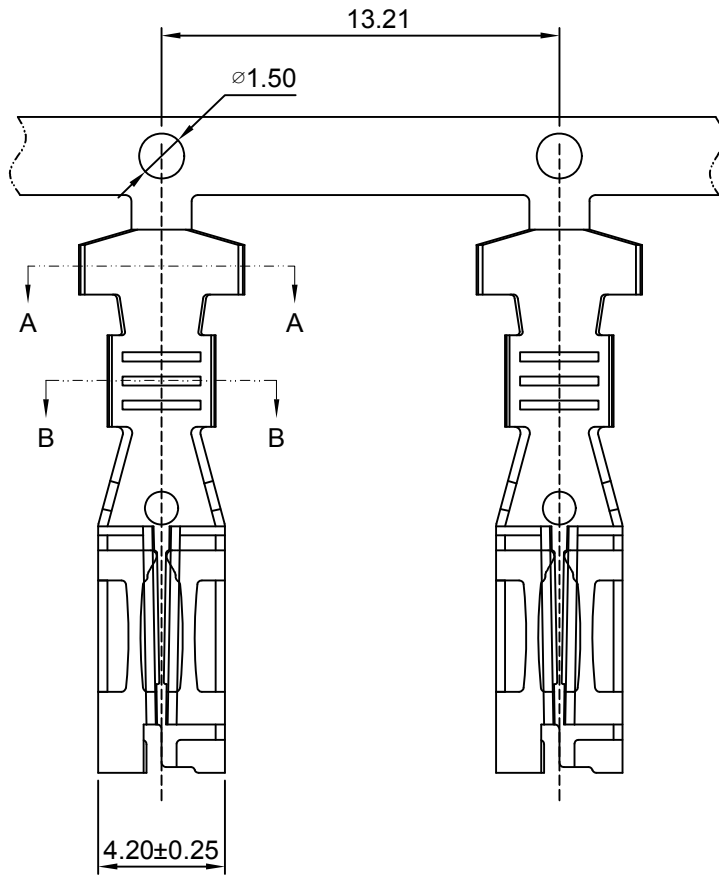

SEC:A-A

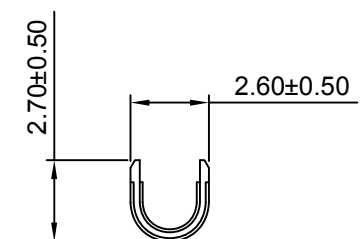

SEC:B-B



Ordering information & Specifications

Unit:mm

Part No	Wire Range	Insultion O.D.	Material	Finish	Qty/reel
HDGC7501AF-TB-L	AWG#14~#16	3.30mm(max)	Brass	Tin over Nickel	5,000 PCS



深圳市华德共创科技有限公司
 SHENZHEN HUADE CO-CREATE TECHNOLOGY CO.,LTD
 TEL : 0755-27129737 FAX : 0755-29940187

-TOLERANCES- UNLESS OTHERWISE SPECIFIED 公差参数表			 	TITLE: 7.50mm Pitch 产品名称: Crimp Terminal				
X.X	±0.30	X.X°	±3°	APPD: 核准: XIE	PART NO: 产品编号: HDGC7501AF-T-L			
X.XX	±0.30	X.XX°	±2°	CHECK: 校对: WANG	DATE	SCALE	UNIT	CODE NUMBER
X.XXX	±0.10	X.XXX°	±1°	DRAW: 绘图: WANG	2017-07-26	4:1	mm	A008

修订 REV	标记 MARK	修改摘要 REVISION DESCRIPTION	签名 SIGNATURE	日期 DATE
AO		NEW RELEASE	WANG	2017-07-26

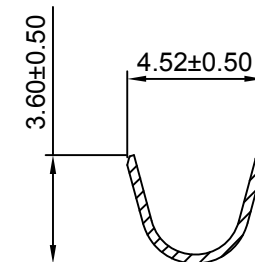
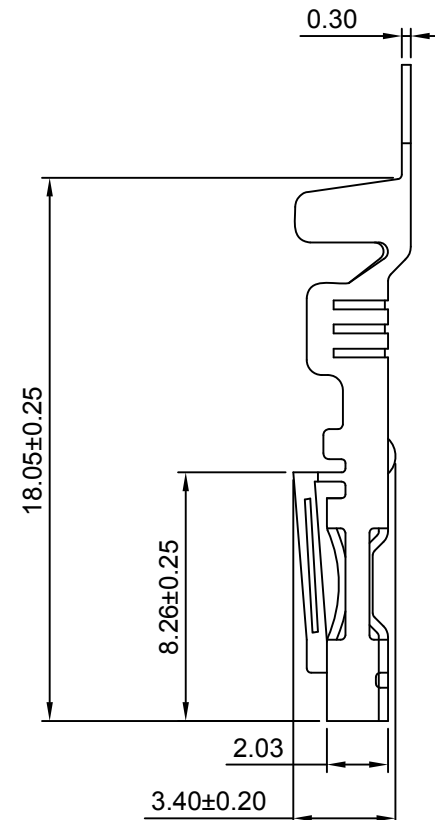
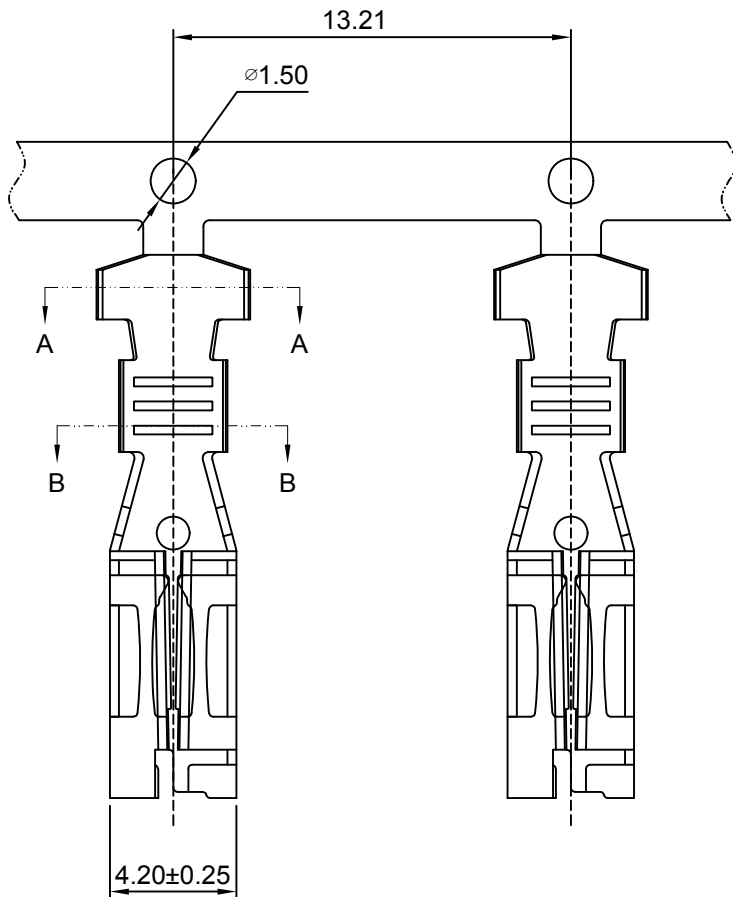

SEC:A-A

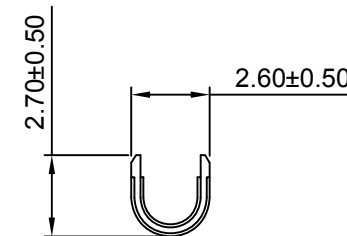

SEC:B-B

Ordering information & Specifications

Part No	Wire Range	Insultion O.D.	Material	Finish	Qty/reel
HDGC7501AF-TB-LL	AWG#18~#20	2.85mm(max)	Brass	Tin over Nickel	5,000 PCS

Unit:mm



深圳市华德共创科技有限公司

SHENZHEN HUADE CO-CREATE TECHNOLOGY CO.,LTD

TEL : 0755-27129737 FAX : 0755-29940187

-TOLERANCES- UNLESS OTHERWISE SPECIFIED 公差参数表					TITLE: 产品名称: 7.50mm Pitch Crimp Terminal			
X.X	±0.30	X.X°	±3°	APPD: 核准: XIE	PART NO: 产品编号: HDGC7501AF-T-LL			
X.XX	±0.30	X.XX°	±2°	CHECK: 校对: WANG	DATE	SCALE	UNIT	CODE NUMBER
X.XXX	±0.10	X.XXX°	±1°	DRAW: 绘图: WANG	2017-07-26	4:1	mm	A008

修订 REV	标记 MARK	修改摘要 REVISION DESCRIPTION	签名 SIGNATURE	日期 DATE
AO		NEW RELEASE	WANG	2017-07-26

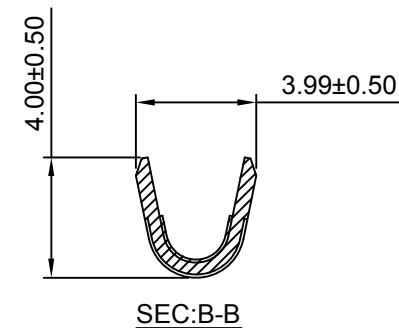
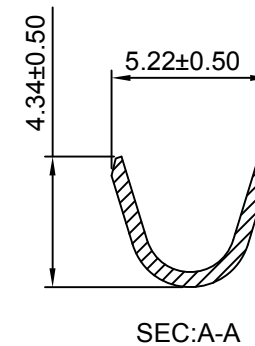
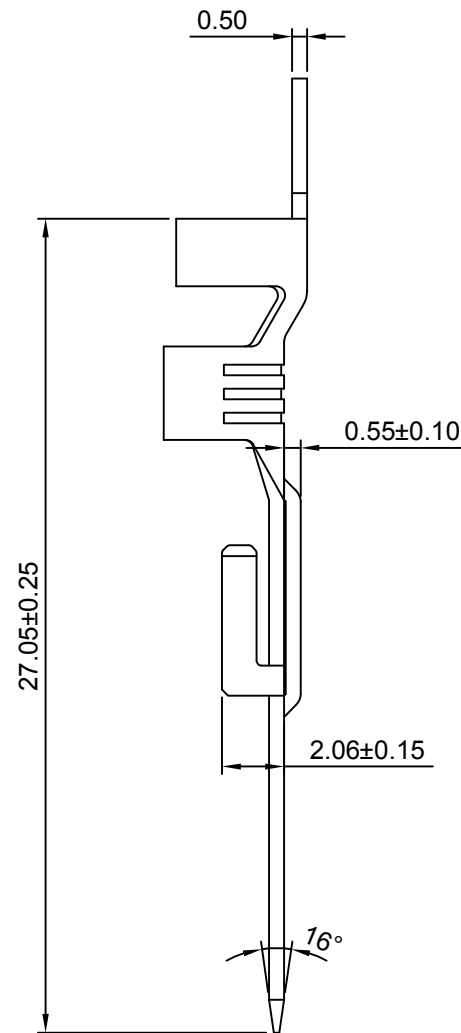
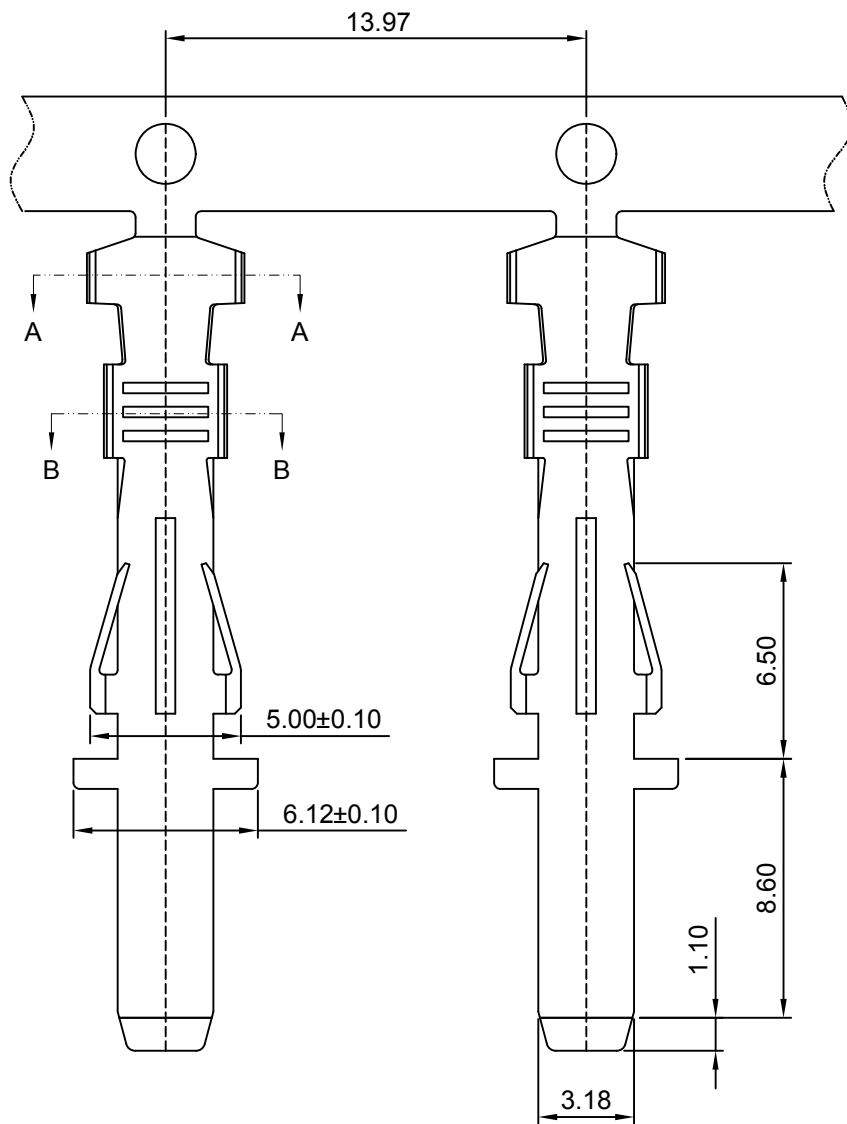

Ordering information & Specifications

Unit:mm

Part No	Wire Range	Insultion O.D.	Material	Finish	Qty/reel
HDGC7501AM-TB-L	AWG#18	3.30mm(max)	Brass	Tin over Nickel	5,000 PCS
HDGC7501AM-TBS-L	AWG#18	3.30mm(max)	Brass	Unplated	5,000 PCS



深圳市华德共创科技有限公司

SHENZHEN HUADE CO-CREATE TECHNOLOGY CO.,LTD

TEL : 0755-27129737 FAX : 0755-29940187

-TOLERANCES- UNLESS OTHERWISE SPECIFIED 公差参数表					TITLE: 7.50mm Pitch 产品名称: Crimp Terminal				
X.X	±0.30	X.X°	±3°	APPD: 核准:	XIE				
X.XX	±0.30	X.XX°	±2°	CHECK: 校对:	WANG	DATE	SCALE	UNIT	CODE NUMBER
X.XXX	±0.10	X.XXX°	±1°	DRAW: 绘图:	WANG	2017-07-26	4:1	mm	A008

修订 REV	标记 MARK	修改摘要 REVISION DESCRIPTION	签名 SIGNATURE	日期 DATE
AO		NEW RELEASE	WANG	2017-07-26

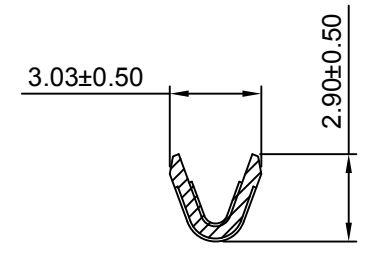
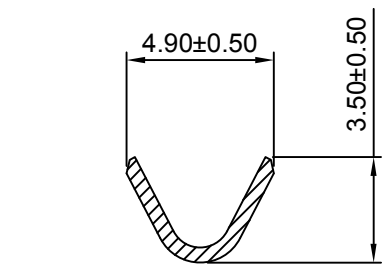
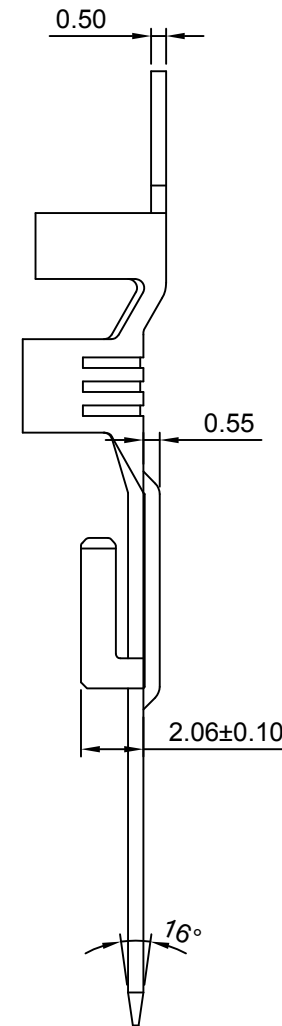
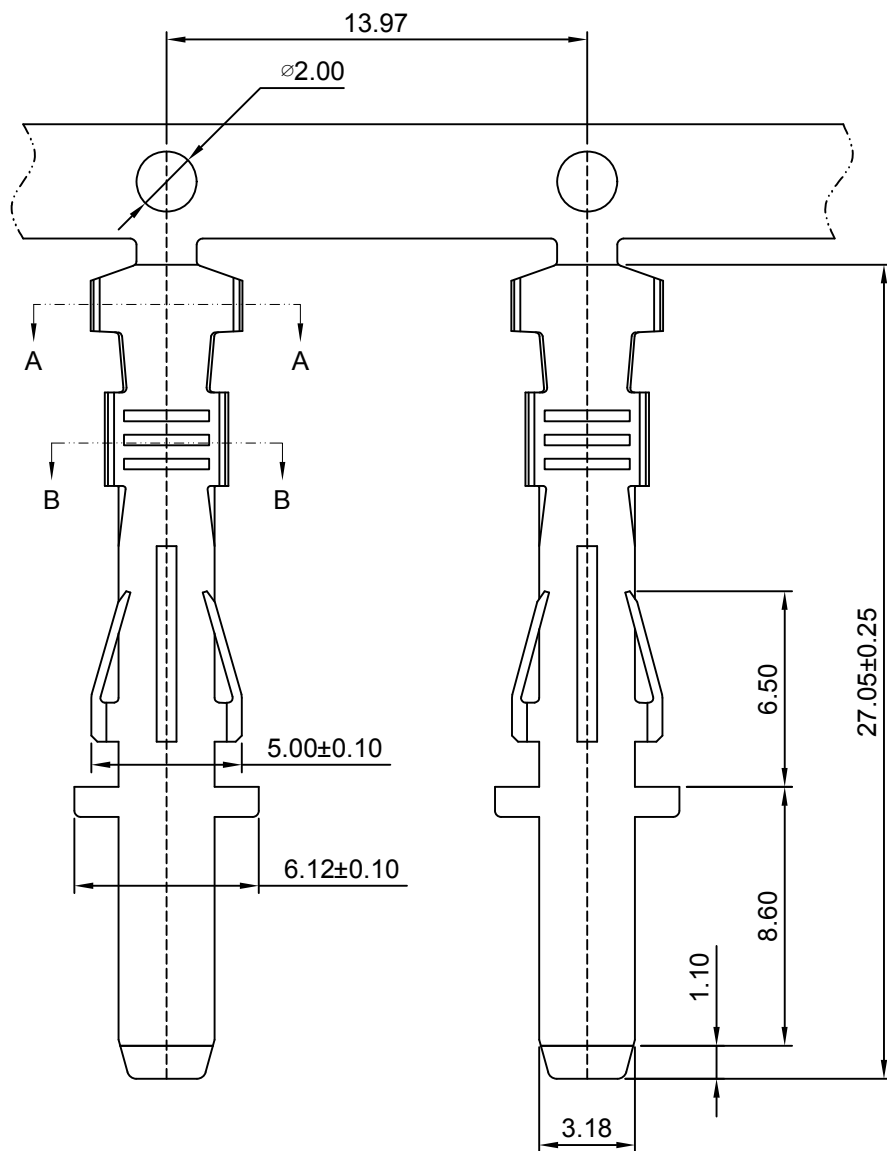

Ordering information & Specifications

Unit:mm

Part No	Wire Range	Insultion O.D.	Material	Finish	Qty/reel
HDGC7501AM-TB-LL	AWG#18~#20	3.30mm(max)	Brass	Tin over Nickel	5,000 PCS
HDGC7501AM-TBS-LL	AWG#18~#20	3.30mm(max)	Brass	Unplated	5,000 PCS



深圳市华德共创科技有限公司

SHENZHEN HUADE CO-CREATE TECHNOLOGY CO.,LTD

TEL : 0755-27129737 FAX : 0755-29940187

-TOLERANCES- UNLESS OTHERWISE SPECIFIED 公差参数表						TITLE: 7.50mm Pitch 产品名称: Crimp Terminal			
X.X	±0.30	X.X°	±3°	APPD: 核准:	XIE	PART NO: 产品编号: HDGC7501AM-T-LL			
X.XX	±0.30	X.XX°	±2°	CHECK: 校对:	WANG	DATE	SCALE	UNIT	CODE NUMBER
X.XXX	±0.10	X.XXX°	±1°	DRAW: 绘图:	WANG	2017-07-26	4:1	mm	A008

修订 REV	标记 MARK	修改摘要 REVISION DESCRIPTION	签名 SIGNATURE	日期 DATE
AO		NEW RELEASE	WANG	2017-07-26

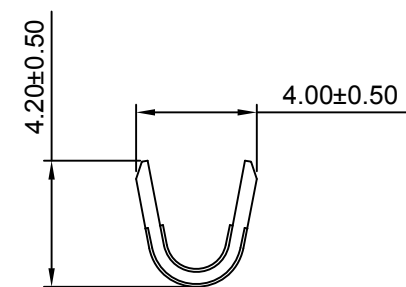
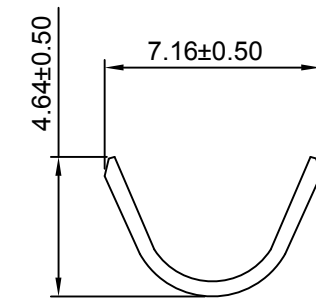
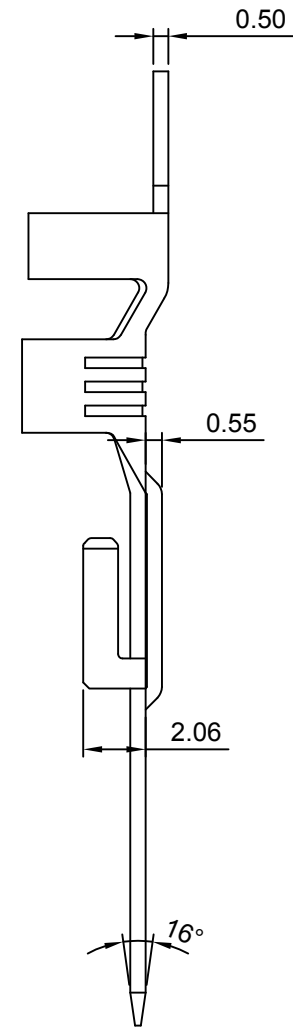
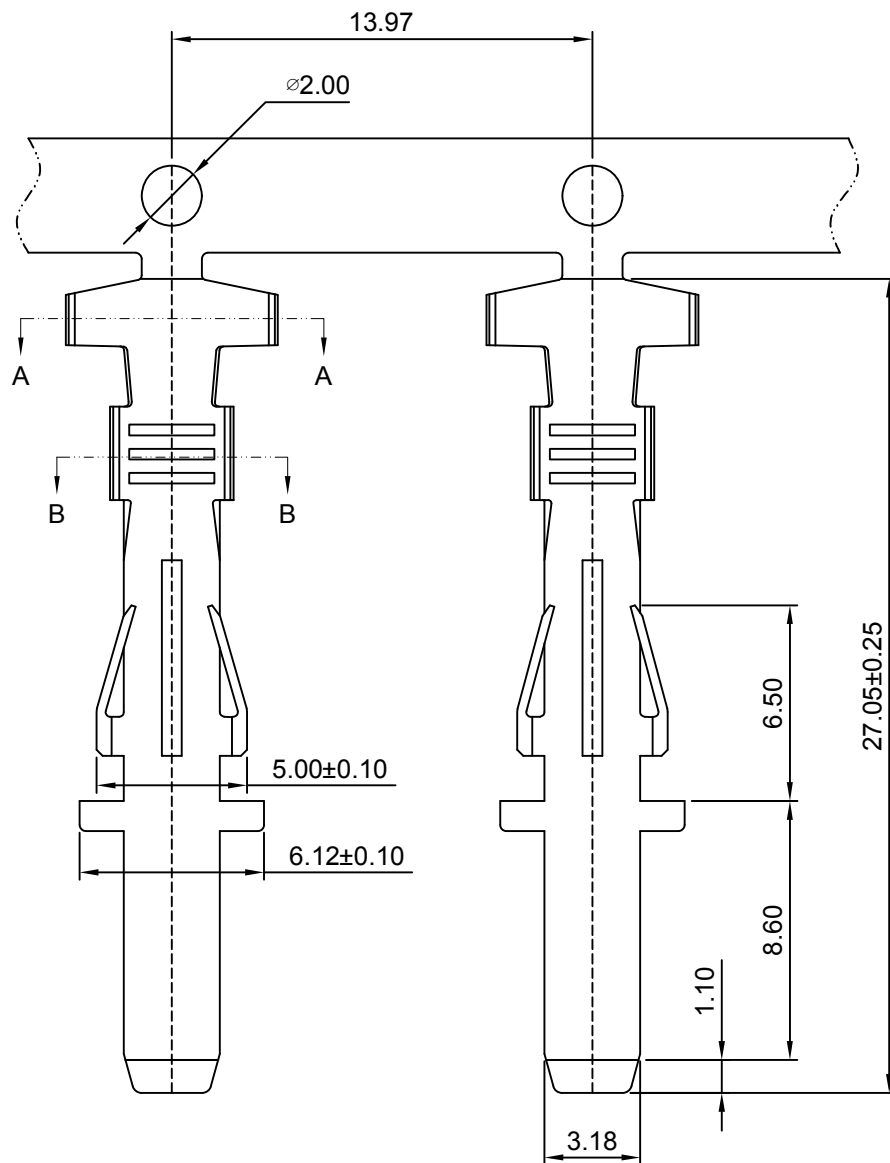

Ordering information & Specifications

Unit:mm

Part No	Wire Range	Insulation O.D.	Material	Finish	Qty/reel
HDGC7501AM-TB-H	DOUBLE AWG#18	4.57mm(max)	Brass	Tin over Nickel	5,000 PCS
HDGC7501AM-TBS-H	DOUBLE AWG#18	4.57mm(max)	Brass	Unplated	5,000 PCS

HDGC 深圳市华德共创科技有限公司
 SHENZHEN HUADE CO-CREATE TECHNOLOGY CO.,LTD
 TEL : 0755-27129737 FAX : 0755-29940187

-TOLERANCES- UNLESS OTHERWISE SPECIFIED 公差参数表					TITLE: 7.50mm Pitch 产品名称: Crimp Terminal			
X.X	±0.30	X.X°	±3°	APPD: 核准:	XIE			
X.XX	±0.30	X.XX°	±2°	CHECK: 校对:	WANG			
X.XXX	±0.10	X.XXX°	±1°	DRAW: 绘图:	WANG			
PART NO: 产品编号:					HDGC7501AM-T-H			
DATE					SCALE	UNIT	CODE NUMBER	
2017-07-26					4:1	mm	A008	

修订 REV	标记 MARK	修改摘要 REVISION DESCRIPTION	签名 SIGNATURE	日期 DATE
AO		NEW RELEASE	WANG	2017-07-26

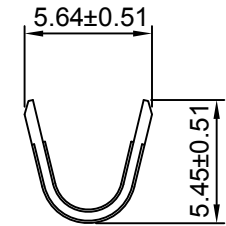
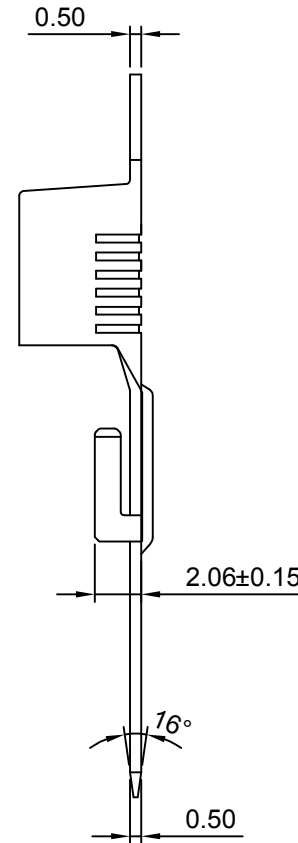
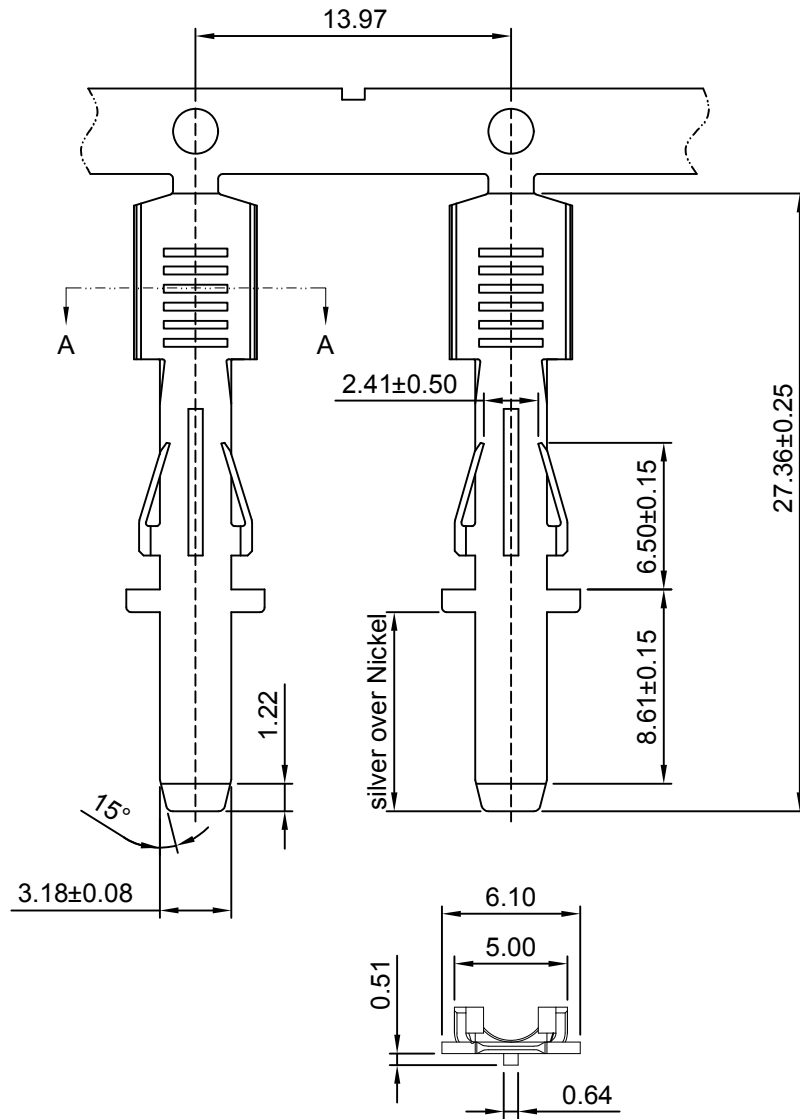

Ordering information & Specifications

Unit:mm

Part No	Wire Range	Insulation O.D.	Material	Finish	Qty/reel
HDGC7501AM-TB-HH	AWG#10~#12	4.57mm(max)	Brass	Tin over Nickel	5,000 PCS
HDGC7501AM-SCA	AWG#10~#12	4.57mm(max)	Copper Alloy	silver over Nickel	5,000 PCS
Finish: Select Silver(100uin) & Select Tin(100uin) Over Nickel Overall					



深圳市华德共创科技有限公司

SHENZHEN HUADE CO-CREATE TECHNOLOGY CO.,LTD

TEL : 0755-27129737 FAX : 0755-29940187

-TOLERANCES- UNLESS OTHERWISE SPECIFIED 公差参数表					TITLE: 产品名称: 7.50mm Pitch Crimp Terminal			
X.X	±0.30	X.X°	±3°	APPD: 核准: XIE	PART NO: 产品编号: HDGC7501AM-SCA			
X.XX	±0.30	X.XX°	±2°	CHECK: 校对: WANG	DATE	SCALE	UNIT	CODE NUMBER
X.XXX	±0.10	X.XXX°	±1°	DRAW: 绘图: WANG	2017-07-26	3:1	mm	A008

修订 REV	标记 MARK	修改摘要 REVISION DESCRIPTION	签名 SIGNATURE	日期 DATE
AO		NEW RELEASE	WANG	2017-07-26

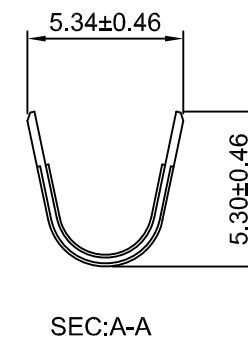
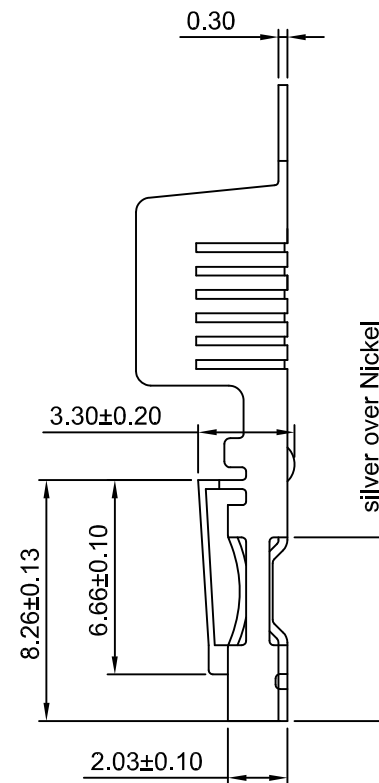
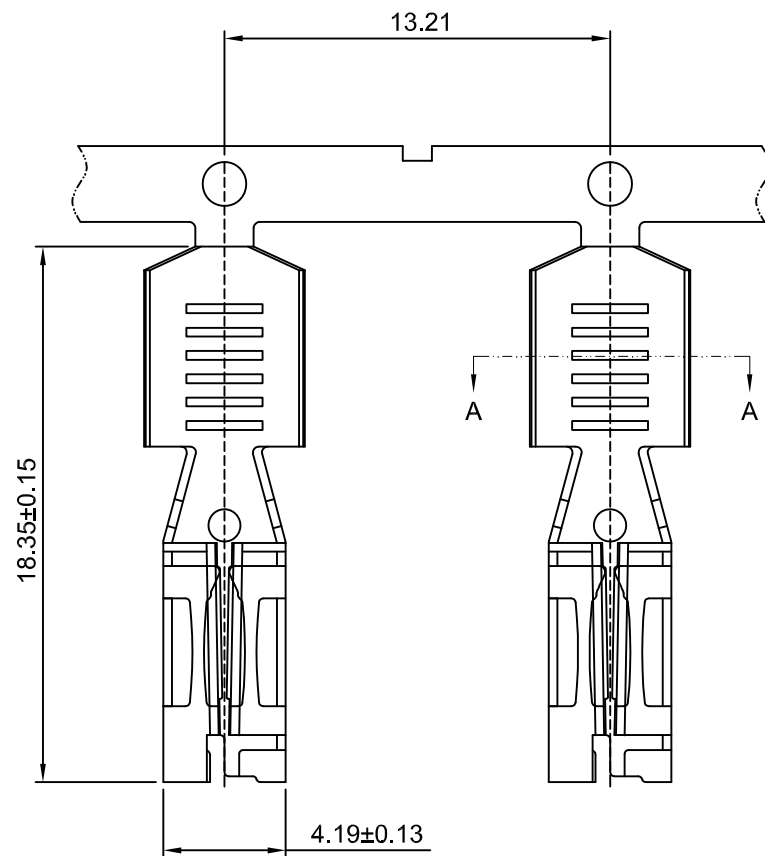

Ordering information & Specifications

Unit:mm

Part No	Wire Range	Insultion O.D.	Material	Finish	Qty/reel
HDGC7501AF-TB-HH	AWG#10~#12	4.57mm(max)	Brass	Tin over Nickel	5,000 PCS
HDGC7501AF-SCA	AWG#10~#12	4.57mm(max)	Copper Alloy	silver over Nickel	5,000 PCS
Finish:Select Silver(100uin) & Select Tin(100uin) Over Nickel Overall					



深圳市华德共创科技有限公司

SHENZHEN HUADE CO-CREATE TECHNOLOGY CO.,LTD

TEL : 0755-27129737 FAX : 0755-29940187

-TOLERANCES- UNLESS OTHERWISE SPECIFIED 公差参数表						TITLE: 产品名称: 7.50mm Pitch Crimp Terminal			
X.X	±0.30	X.X°	±3°	APPD: 核准:	XIE	PART NO: 产品编号: HDGC7501AF-SCA			
X.XX	±0.30	X.XX°	±2°	CHECK: 校对:	WANG	DATE	SCALE	UNIT	CODE NUMBER
X.XXX	±0.10	X.XXX°	±1°	DRAW: 绘图:	WANG	2017-07-26	4:1	mm	A008

修订 REV	标记 MARK	修改摘要 REVISION DESCRIPTION	签名 SIGNATURE	日期 DATE
AO		NEW RELEASE	WANG	2017-07-26

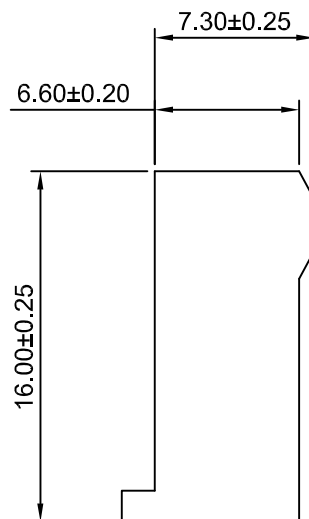
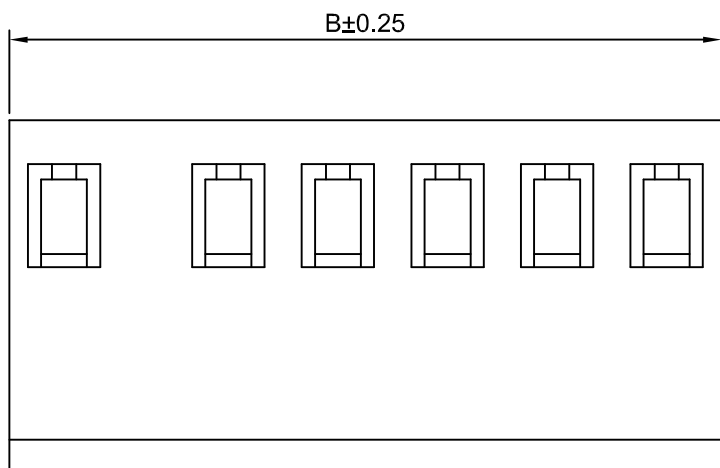
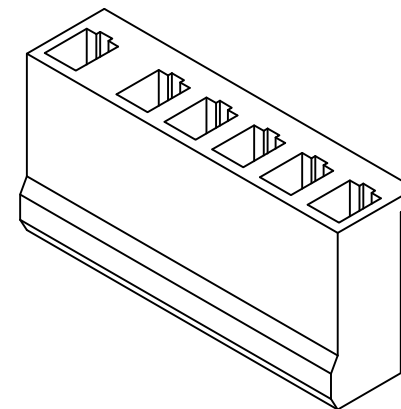
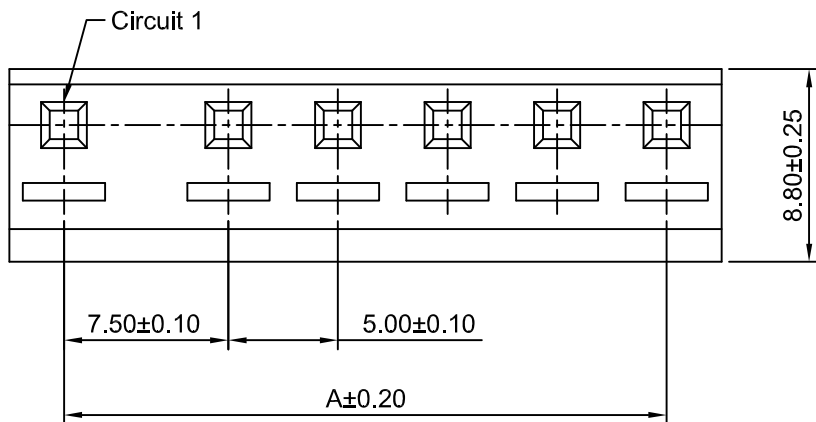

SPECIFICATIONS:

Current Rating: 7A AC,DC
Voltage Rating: 250V AC,DC
Temperature Range: -25°C~+85°C
Contact Resistance: 10mΩ Max
Insulation Resistance: 1000MΩ Min
Withstanding Voltage: 1500V AC/minute
Material: Nylon 66,UL94V-2(Natural)

Ordering Information & Dimensions

Circuits	Dimensions(mm)		Circuits	Dimensions(mm)	
	A	B		A	B
2P	7.50	12.50	5P	22.50	27.50
3P	12.50	17.50	6P	27.50	32.50
4P	17.50	22.50			



深圳市华德共创科技有限公司

SHENZHEN HUADE CO-CREATE TECHNOLOGY CO.,LTD

TEL : 0755-27129737 FAX : 0755-29940187

-TOLERANCES- UNLESS OTHERWISE SPECIFIED 公差参数表						TITLE: 7.50-5.00mm Pitch 产品名称: Housing			
X.X	±0.30	X.X°	±3°	APPD: 核准:	XIE	PART NO: 产品编号: HDGC7501H-XP			
X.XX	±0.30	X.XX°	±2°	CHECK: 校对:	WANG	DATE	SCALE	UNIT	CODE NUMBER
X.XXX	±0.10	X.XXX°	±1°	DRAW: 绘图:	WANG	2017-07-26	3:1	mm	A008

修订 REV	标记 MARK	修改摘要 REVISION DESCRIPTION	签名 SIGNATURE	日期 DATE
AO		NEW RELEASE	WANG	2017-07-26

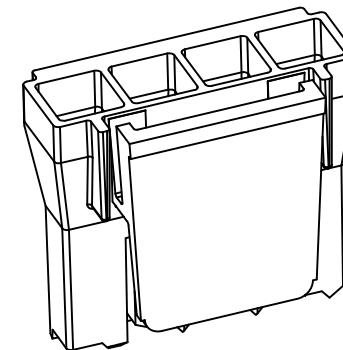
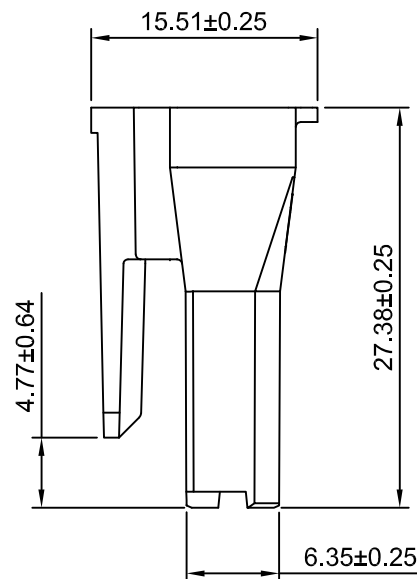
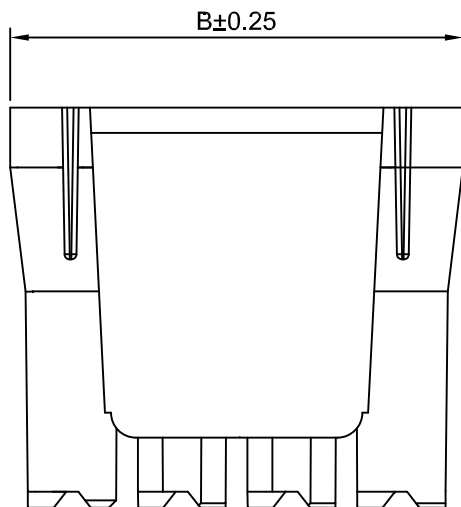
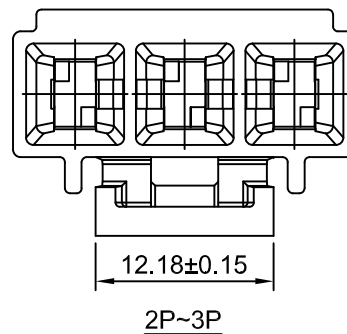
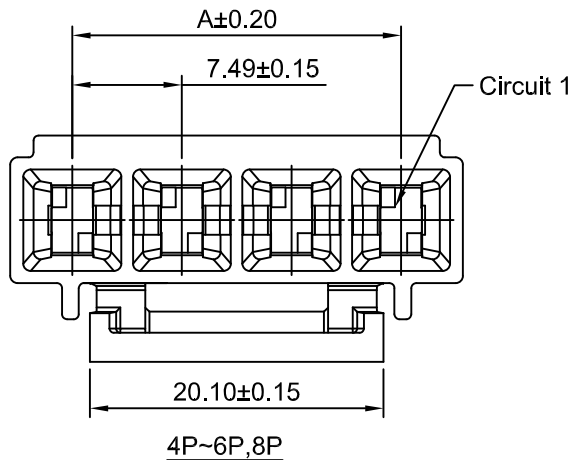

Ordering Information:
 HDGC7501HFA-XP - ***
 1 2

- 1.Part No.
 2.Material:
 (Blank):Nylon 66,UL94V-0/Black
 V2:Nylon 66,UL94V-2/Natural
 GWT:Nylon 66,UL94V-0,GWT 750°C/Black

SPECIFICATIONS:

Current Rating: 34A AC,DC
 Voltage Rating: 600V AC,DC
 Temperature Range: -25°C~+85°C
 Contact Resistance: 10mΩ Max
 Insulation Resistance: 1000MΩ Min
 Withstanding Voltage: 1500V AC/minute
 Material: Nylon 66,UL94V-0(Black)

Ordering Information & Dimensions

Circuits	Dimensions(mm)		Circuits	Dimensions(mm)	
	A	B		A	B
2P	7.49	15.98	5P	29.96	38.45
3P	14.98	23.47	6P	37.45	45.94
4P	22.47	30.96	8P	52.43	60.92



深圳市华德共创科技有限公司

SHENZHEN HUADE CO-CREATE TECHNOLOGY CO.,LTD

TEL : 0755-27129737 FAX : 0755-29940187

-TOLERANCES- UNLESS OTHERWISE SPECIFIED 公差参数表				TITLE: 产品名称: 7.49mm Pitch Housing	
X.X	±0.30	X.X°	±3°	APPD: 核准:	XIE
X.XX	±0.30	X.XX°	±2°	CHECK: 校对:	WANG
X.XXX	±0.10	X.XXX°	±1°	DRAW: 绘图:	WANG
PART NO: 产品编号:				HDGC7501HFA-XP	
DATE		SCALE	UNIT	CODE NUMBER	
2017-07-26		2:1	mm	A008	

修订 REV	标记 MARK	修改摘要 REVISION DESCRIPTION	签名 SIGNATURE	日期 DATE
AO		NEW RELEASE	WANG	2017-07-26

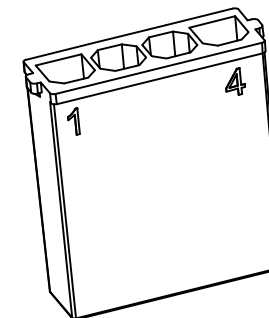
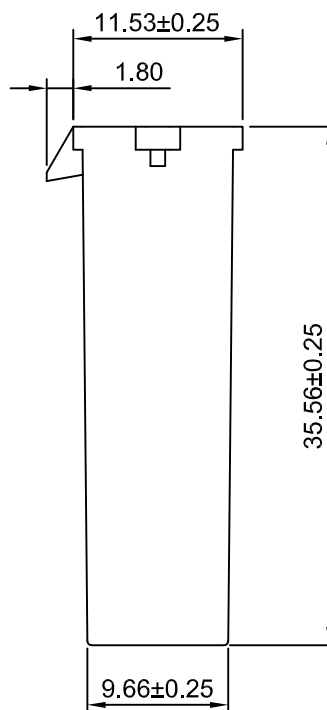
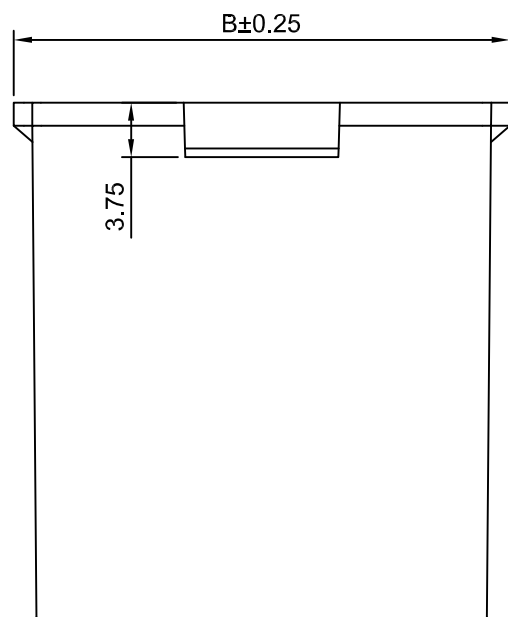
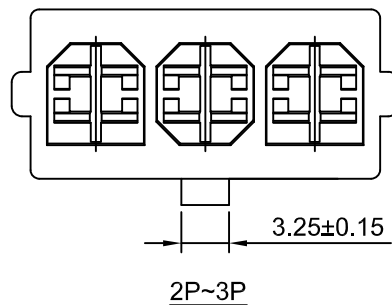
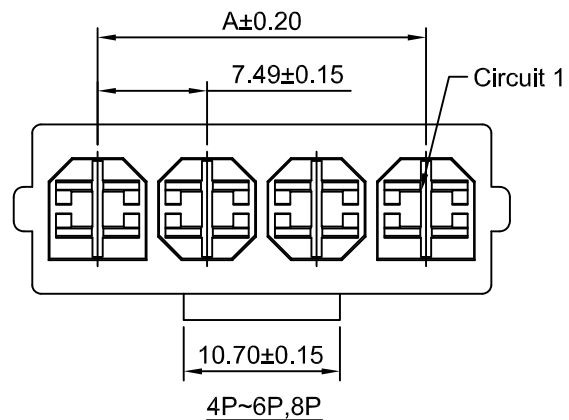

Ordering Information:
HDGC7501HMA-XP - ***
1 2

- 1.Part No.
2.Material:
(Blank):Nylon 66,UL94V-0/Black
V0:Nylon 66,UL94V-2/Natural
GWT:Nylon 66,UL94V-0,GWT 750°C/Black

SPECIFICATIONS:

Current Rating: 34A AC,DC
Voltage Rating: 600V AC,DC
Temperature Range: -25°C~+85°C
Contact Resistance: 10mΩ Max
Insulation Resistance: 1000MΩ Min
Withstanding Voltage: 1500V AC/minute
Material: Nylon 66,UL94V-0(Black)

Ordering Information & Dimensions

Circuits	Dimensions(mm)		Circuits	Dimensions(mm)	
	A	B		A	B
2P	7.49	15.86	5P	29.96	38.33
3P	14.98	23.35	6P	37.45	45.82
4P	22.47	30.84	8P	52.43	60.80



深圳市华德共创科技有限公司

SHENZHEN HUADE CO-CREATE TECHNOLOGY CO.,LTD

TEL : 0755-27129737 FAX : 0755-29940187

-TOLERANCES- UNLESS OTHERWISE SPECIFIED 公差参数表					TITLE: 7.49mm Pitch Housing 产品名称:			
X.X	±0.30	X.X° ±3°	APPD: 核准:	XIE	PART NO: 产品编号: HDGC7501HMA-XP			
X.XX	±0.30	X.XX° ±2°	CHECK: 校对:	WANG	DATE	SCALE	UNIT	CODE NUMBER
X.XXX	±0.10	X.XXX° ±1°	DRAW: 绘图:	WANG	2017-07-26	2:1	mm	A008

修订 REV	标记 MARK	修改摘要 REVISION DESCRIPTION	签名 SIGNATURE	日期 DATE
AO		NEW RELEASE	WANG	2017-07-26

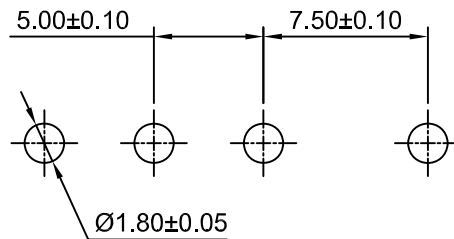
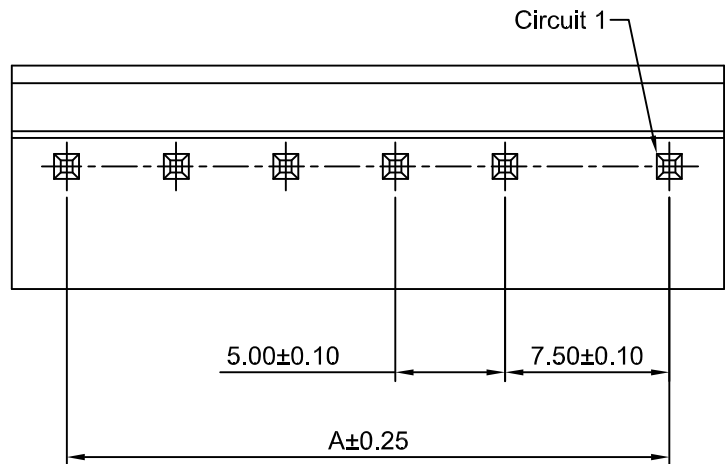

P.C.B LAYOUT

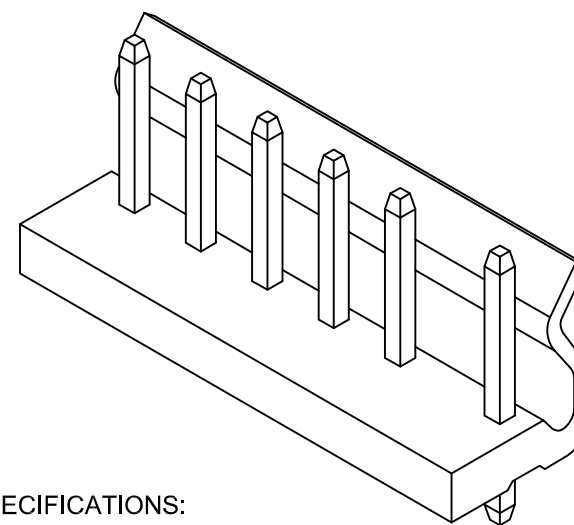

SPECIFICATIONS:

Current Rating: 7A AC,DC
Voltage Rating: 250V AC,DC
Temperature Range: -25°C~+85°C
Contact Resistance: 10mΩ Max
Insulation Resistance: 1000MΩ Min
Withstanding Voltage: 1500V AC/minute
Pin Material: Brass/Tin over Nickel
Material: Nylon 66,UL94V-2(Natural)

Ordering Information & Dimensions

Circuits	Dimensions(mm)		Circuits	Dimensions(mm)	
	A	B		A	B
2P	7.50	12.50	5P	22.50	27.50
3P	12.50	17.50	6P	27.50	32.50
4P	17.50	22.50			

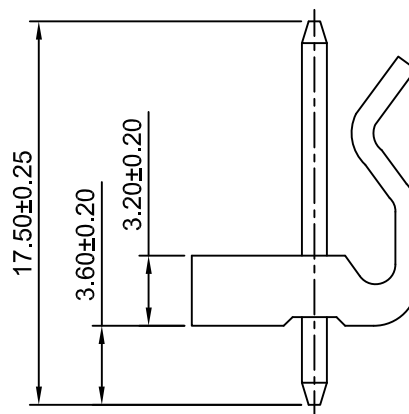
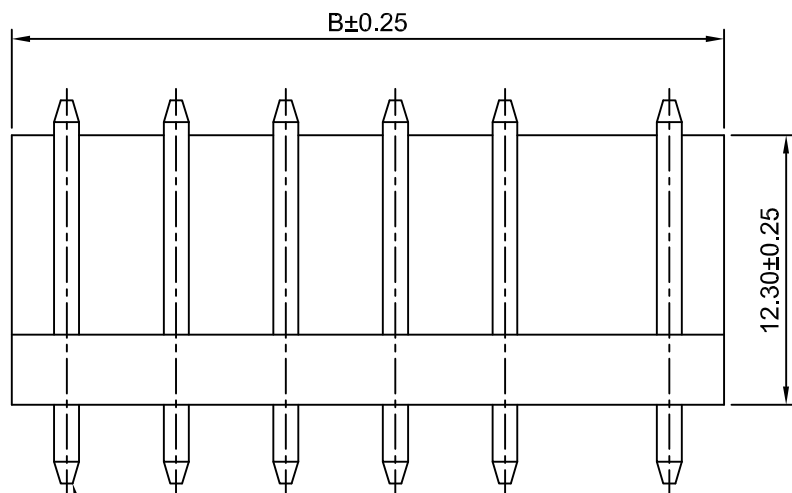

PIN 1.14 SQ



深圳市华德共创科技有限公司
SHENZHEN HUADE CO-CREATE TECHNOLOGY CO.,LTD
TEL : 0755-27129737 FAX : 0755-29940187

-TOLERANCES- UNLESS OTHERWISE SPECIFIED 公差参数表				 	TITLE: 7.50-5.00mm Pitch 产品名称: 180° Wafer			
X.X	±0.30	X.X°	±3°	APPD: 核准:	XIE			
X.XX	±0.30	X.XX°	±2°	CHECK: 校对:	WANG			
X.XXX	±0.10	X.XXX°	±1°	DRAW: 绘图:	WANG			
				PART NO: 产品编号:	HDGC7501WV-XP			
				DATE	SCALE	UNIT	CODE NUMBER	
				2017-07-26	3:1	mm	A008	

修订 REV	标记 MARK	修改摘要 REVISION DESCRIPTION	签名 SIGNATURE	日期 DATE
AO		NEW RELEASE	WANG	2017-07-26

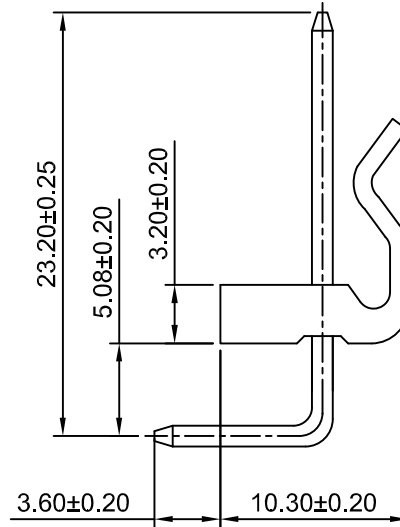
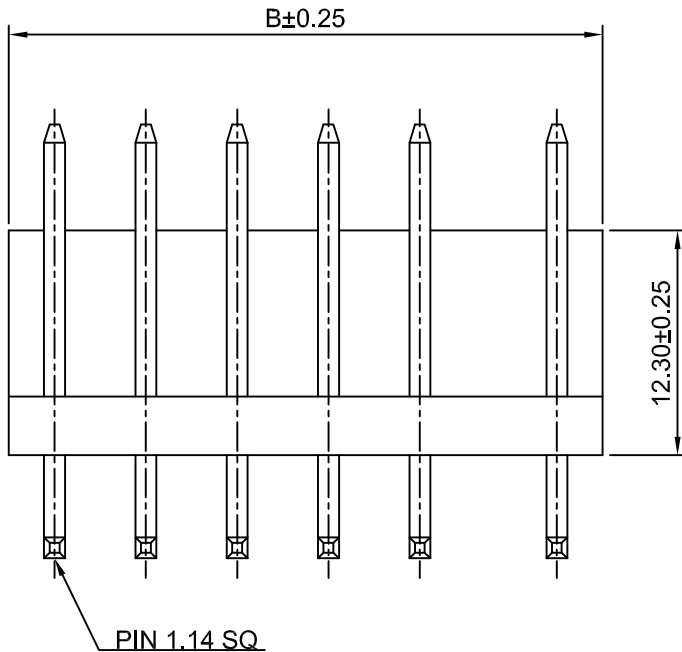
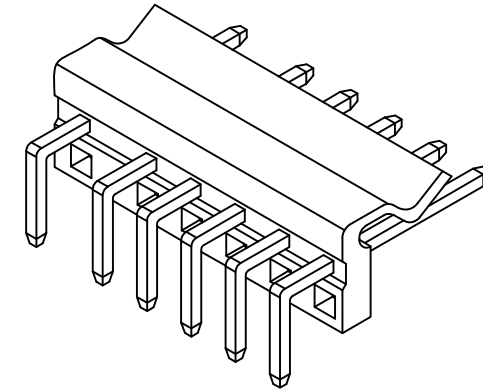
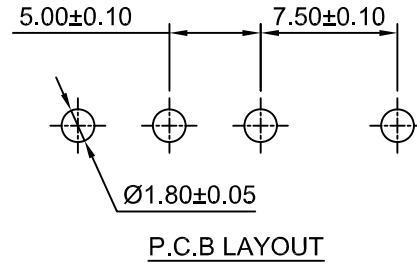
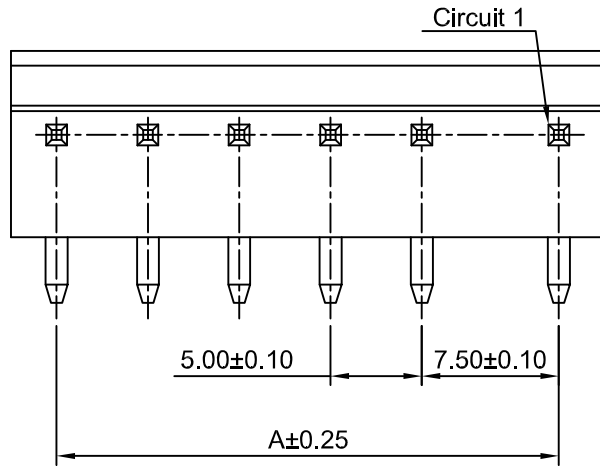

SPECIFICATIONS:

Current Rating: 7A AC,DC
Voltage Rating: 250V AC,DC
Temperature Range: -25°C~+85°C
Contact Resistance: 10mΩ Max
Insulation Resistance: 1000MΩ Min
Withstanding Voltage: 1500V AC/minute
Pin Material: Brass/Tin over Nickel
Material: Nylon 66,UL94V-2(White)

Ordering Information & Dimensions

Circuits	Dimensions(mm)		Circuits	Dimensions(mm)	
	A	B		A	B
2P	7.50	12.50	5P	22.50	27.50
3P	12.50	17.50	6P	27.50	32.50
4P	17.50	22.50			



深圳市华德共创科技有限公司

SHENZHEN HUADE CO-CREATE TECHNOLOGY CO.,LTD

TEL : 0755-27129737 FAX : 0755-29940187

-TOLERANCES- UNLESS OTHERWISE SPECIFIED 公差参数表						TITLE: 7.50-5.00mm Pitch 产品名称: 90° Wafer			
X.X	±0.30	X.X°	±3°	APPD: 核准:	XIE	PART NO: 产品编号: HDGC7501WR-XP			
X.XX	±0.30	X.XX°	±2°	CHECK: 校对:	WANG	DATE	SCALE	UNIT	CODE NUMBER
X.XXX	±0.10	X.XXX°	±1°	DRAW: 绘图:	WANG	2017-07-26	2.5:1	mm	A008

修订 REV	标记 MARK	修改摘要 REVISION DESCRIPTION	签名 SIGNATURE	日期 DATE
AO		NEW RELEASE	WANG	2017-07-26

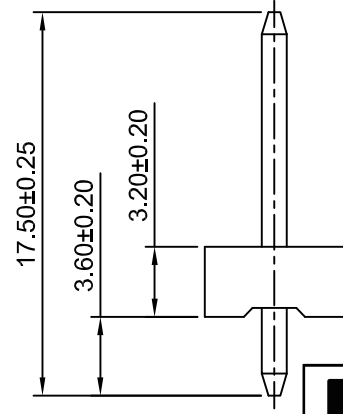
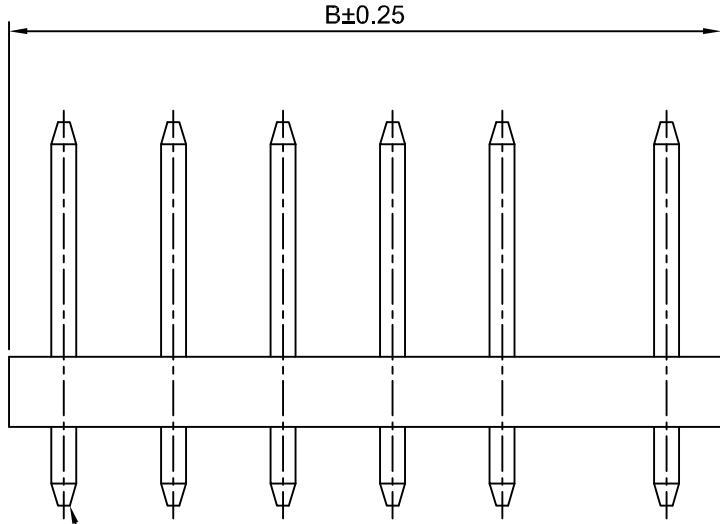
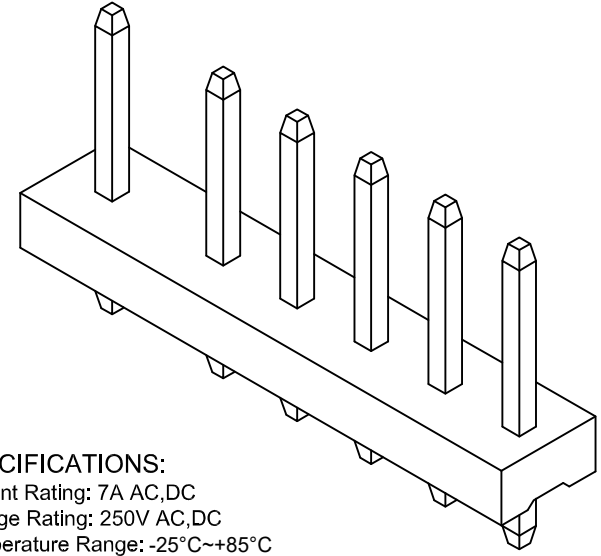
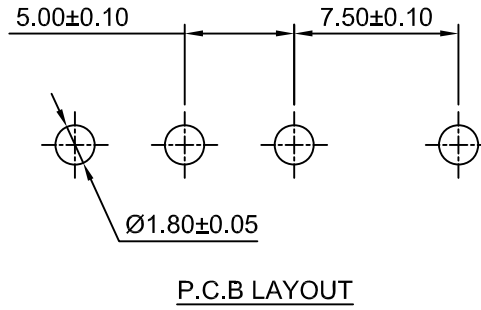
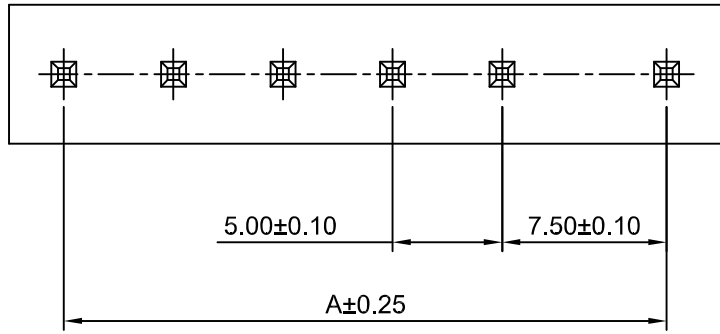

SPECIFICATIONS:

- Current Rating: 7A AC,DC
- Voltage Rating: 250V AC,DC
- Temperature Range: -25°C~+85°C
- Contact Resistance: 10mΩ Max
- Insulation Resistance: 1000MΩ Min
- Withstanding Voltage: 1500V AC/minute
- Pin Material: Brass/Tin over Nickel
- Material: Nylon 66,UL94V-2(White)

Ordering Information & Dimensions

Circuits	Dimensions(mm)		Circuits	Dimensions(mm)	
	A	B		A	B
2P	7.50	12.50	5P	22.50	27.50
3P	12.50	17.50	6P	27.50	32.50
4P	17.50	22.50			



深圳市华德共创科技有限公司

SHENZHEN HUADE CO-CREATE TECHNOLOGY CO.,LTD
TEL : 0755-27129737 FAX : 0755-29940187

-TOLERANCES- UNLESS OTHERWISE SPECIFIED 公差参数表				TITLE: 产品名称: 7.50-5.00mm Pitch 180° Wafer	
X.X	±0.30	X.X°	±3°	APPD: 核准:	XIE
X.XX	±0.30	X.XX°	±2°	CHECK: 校对:	WANG
X.XXX	±0.10	X.XXX°	±1°	DRAW: 绘图:	WANG
PART NO: 产品编号:		HDGC7501WVA-XP			
DATE	SCALE	UNIT	CODE NUMBER		
2017-07-26	3:1	mm	A008		

修订 REV	标记 MARK	修改摘要 REVISION DESCRIPTION	签名 SIGNATURE	日期 DATE
AO		NEW RELEASE	WANG	2017-07-26

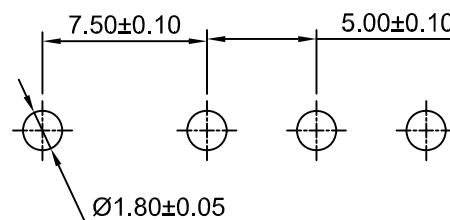
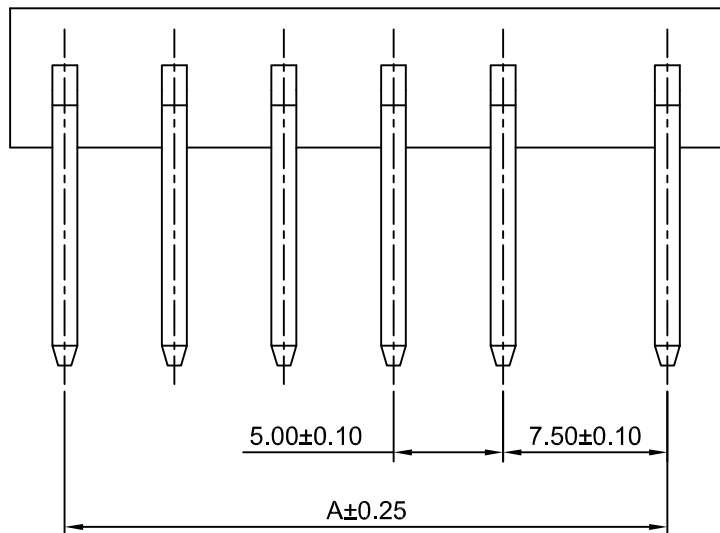

P.C.B LAYOUT

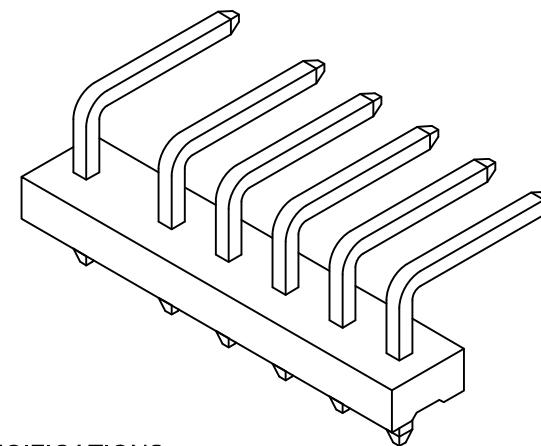

SPECIFICATIONS:

Current Rating: 7A AC,DC
Voltage Rating: 250V AC,DC
Temperature Range: -25°C~+85°C
Contact Resistance: 10mΩ Max
Insulation Resistance: 1000MΩ Min
Withstanding Voltage: 1500V AC/minute
Pin Material: Brass/Tin over Nickel
Material: Nylon 66,UL94V-2(White)

Ordering Information & Dimensions

Circuits	Dimensions(mm)		Circuits	Dimensions(mm)	
	A	B		A	B
2P	7.50	12.50	5P	22.50	27.50
3P	12.50	17.50	6P	27.50	32.50
4P	17.50	22.50			

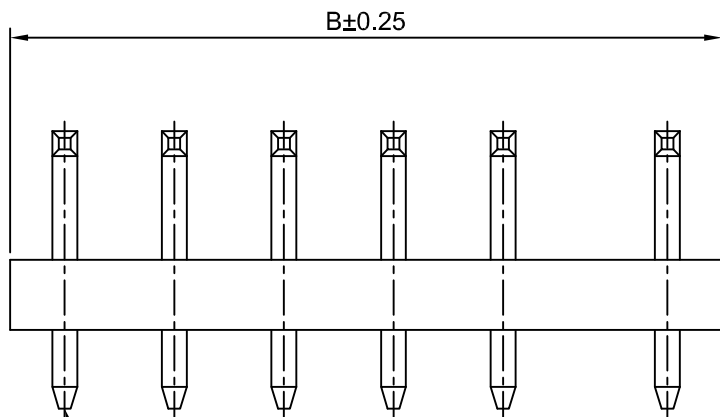

PIN 1.14 SQ

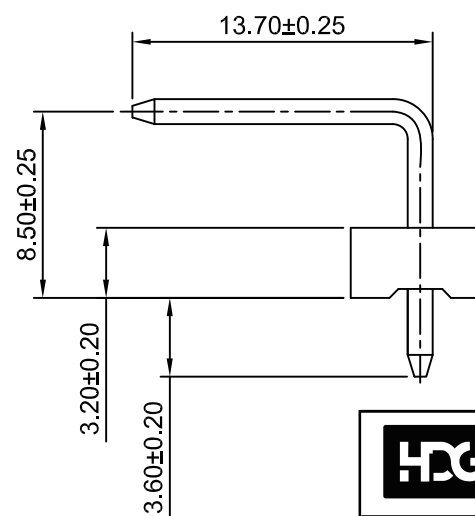

深圳市华德共创科技有限公司

SHENZHEN HUADE CO-CREATE TECHNOLOGY CO.,LTD

TEL : 0755-27129737 FAX : 0755-29940187

-TOLERANCES- UNLESS OTHERWISE SPECIFIED 公差参数表						TITLE: 7.50-5.00mm Pitch 产品名称: 90° Wafer			
X.X	±0.30	X.X°	±3°	APPD: 核准:	XIE	PART NO: 产品编号: HDGC7501WRA-XP			
X.XX	±0.30	X.XX°	±2°	CHECK: 校对:	WANG	DATE	SCALE	UNIT	CODE NUMBER
X.XXX	±0.10	X.XXX°	±1°	DRAW: 绘图:	WANG	2017-07-26	3:1	mm	A008